



# 防爆热电偶使用说明

Explosion Proof Thermocouple Instruction



**CN BOILER ENGINEERING SOLUTION LLC**

# 防爆热电阻

## Explosion-proof Thermal Resistance

### 应用

通常和显示仪表、记录仪表、电子计算机等配套使用。直接测量各种生产现场存在碳氢化合物等爆炸物的 -200 °C -500 °C 范围内液体、蒸汽和气体介质以及固体表面温度。

### 特点

- 1、压簧式感温元件、抗振性能好；
- 2、测量精确度高；
- 3、毋须补偿导线，节省费用；
- 4、进口薄膜电阻元件，性能可靠稳定；

### 工作原理

隔爆热电阻四利用物间隙隔爆原理，设计具有足够强度的接线盒等部件，将所有会产生火花、电弧和危险温度的零部件都密封在接线盒腔内，当腔内发生爆炸的时，能通过接合面间隙熄火和冷却，使爆炸后的火焰和温度传不到腔外，从而进行隔爆。

### 主要技术参数

#### 产品执行标准

- IEC751
- JB/T8622-1997
- JB/T8623-1997
- JB/T8518-1991

### 常温绝缘电阻

防爆热电阻在环境温度为 15-35 °C，相对湿度不大于 80%，试验电压为 10~100V（直流）电极与外套管之间的绝缘电阻  $\geq 100M\Omega$

### 测温范围及允差 Measuring Range & Tolerance

型号 Type	分度号 Graduation	测温范围 Measuring Range °C	精度等级 Accuracy	允许偏差 Tolerance
WZP	Pt100	-200 - +500	A 级	$\pm (0.15+0.002)   t  $
			B 级	$\pm (0.30+0.005)   t  $
WZC	Cu50 Cu100	-50 - +100	-	$\pm (0.30+0.005)   t  $

注：t 为感温元件实测温度绝对值

Remarks:t is absolute value actually tested with thermal sensor

### Application

It is usually connected with display meter, recording meter and computer, etc. to directly measure temperature of liquid, vapor, gas and solid surface ranging from -200 °C to 500 °C with explosives such as hydrocarbon on production spot.

### Features

- 1.Spring thermal element with good shock-proof performance;
- 2.High measuring accuracy;
- 3.No compensational wire, spare cost;
- 4.Imported film resistor with high reliability and stability;

### Operation Theory

Explosion-proof thermal resistance has a junction box of enough strength with gaps inside it. All spare parts which might produce spark, electric arc, and dangerous high temperature are sealed in the junction box. When explosion within the box happens, fine and high temperature caused by explosion could be extinguished and cooled. Thus, explosion separation could be realized.

### Main Technical Parameters

#### Executive Standard

- IEC751
- JB/T8622-1997
- JB/T8623-1997
- JB/T8518-1991

### Insulation Resistance at Normal Temperature

The insulation resistance between electrode and protection tube of the thermocouple shall be no less than 100M $\Omega$  under condition that environment temperature is 15~35 °C, relative humidity is no more than 80%, and testing voltage is D.C. 10~100V.

## 防爆分组形式

### Indication of Explosion-proof Function



## 电气设备类别

- I 类——煤矿井下用电气设备
- II 类——工厂用电气设备

## Electric Equipment Category

- I - Electric Equipment for Coal Mine Well
- II - Electric Equipment for Plant

## 防爆等级

防爆热电偶的防爆等级按其使用爆炸性气体混合物最大试验安全间隙分为 A、B、C 三级。

## Explosion-proof Class

It is divided into grade A, Band C according to maximum test safety gap in explosive gas compound.

类别 Category	级别 Class	最大试验安全间隙 (MESG) mm Maximum Test Safety Gap
II	A	$0.9 \leq \text{MESG}$
	B	$0.5 < \text{MESG} < 0.9$
	C	$\text{MESG} \leq 0.5$

## 温度组别

防爆热电偶的温度组别按其外露部分允许最高表面温度分为 T1-T6

## Temperature Group

It includes T1-T6 according to the maximum temperature of open part.

温度组别 Temperature Group	允许最高表面温度℃ Max. Surface Temperature Allowed
T1	450
T2	300
T3	200
T4	135
T5	100
T6	85

接线盒形式 Junction Box Figure

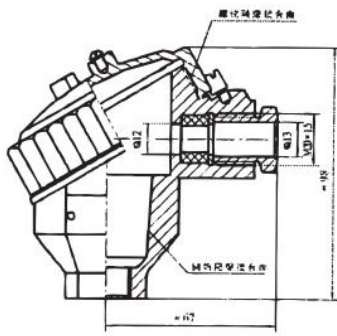

d II BT □级  
Class d II BT □

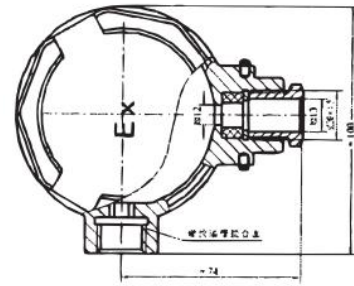

d II CT □级  
Class d II CT □

安装端子形式 Terminal Figure

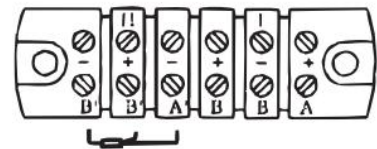
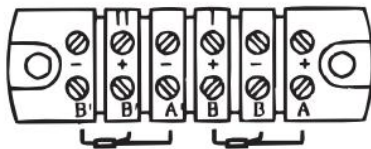

# 型号命名方法

## Type Naming Method

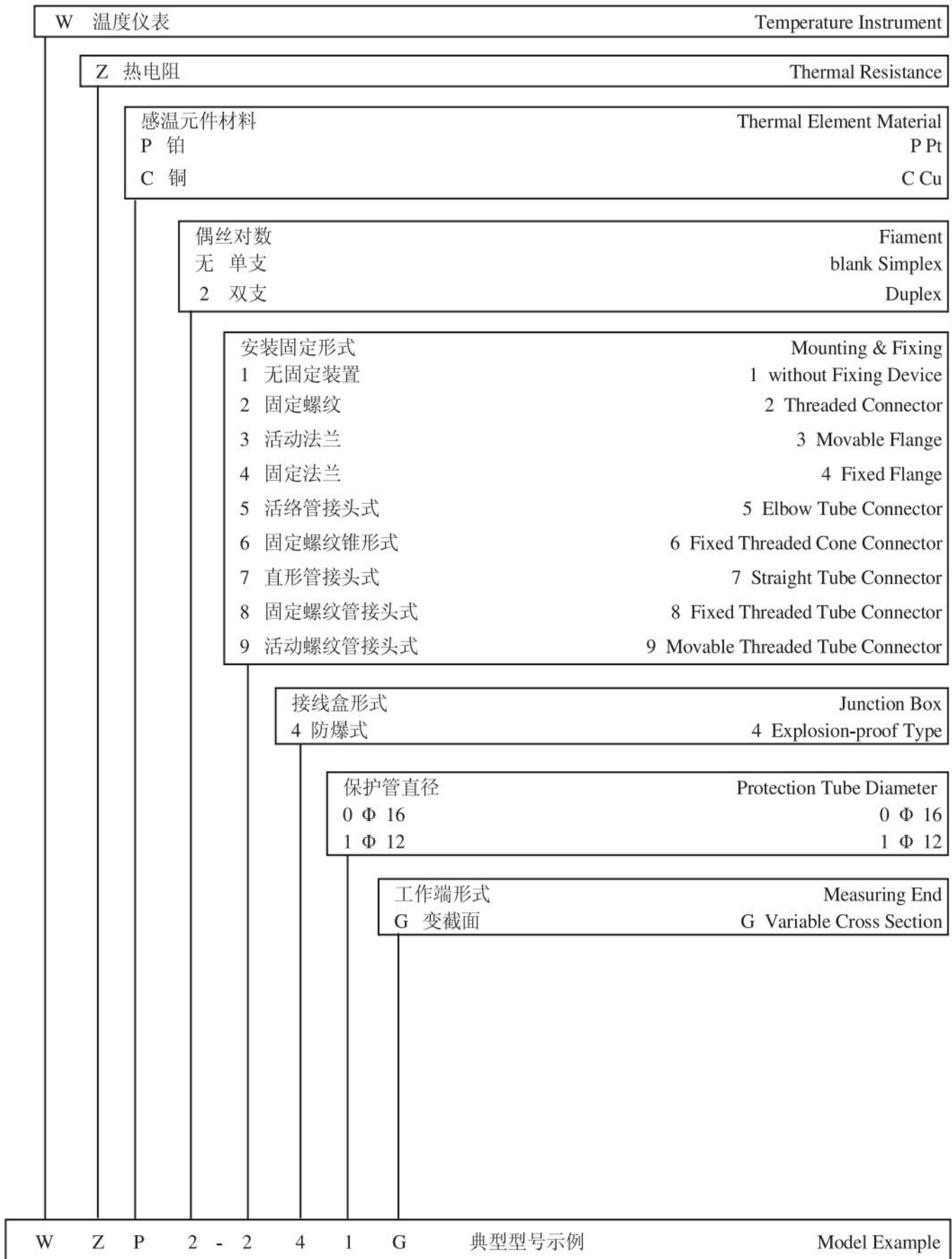

安装形式 Installation Figure

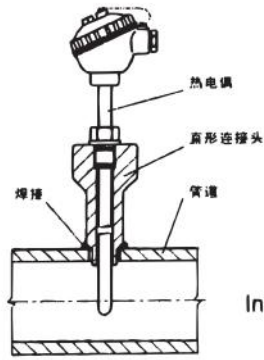

垂直管道安装形式  
Installation in Horizontal  
Tube

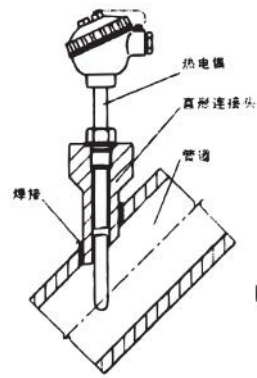

倾斜管道安装形式  
Installation in Sliding  
Tube

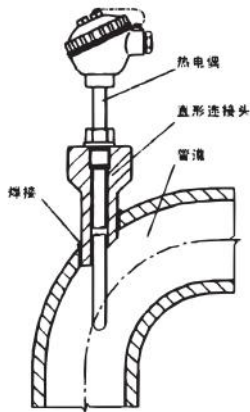

弯曲管道安装形式  
Installation in  
Bending Tube

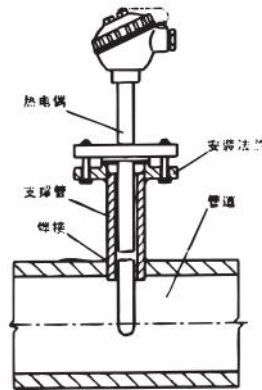

法兰安装形式  
Flange Installation

直接接头 Straight Connector

代号 Code	M	D	D <sub>1</sub>	D <sub>2</sub>	d	h	H
TH48A	M12*1.5	Φ32	Φ18	Φ12	Φ7	27	60.120
TH48B	M16*1.5	Φ36	Φ18	Φ14	Φ7	27	80
TH48C	M20*1.5	Φ40	Φ18	Φ14	Φ7	27	60
TH48D	M27*2	Φ47	Φ28	Φ22	Φ17	32	60
TH48E	M33*2	Φ55	Φ36	Φ30	Φ21	34	120
TH48F	NPT1/2	Φ39	Φ27	Φ21	Φ16	35	60 120
TH48G	NPT3/4	Φ47	Φ31	Φ25	Φ20	40	
TH48H	NPT1	Φ47	Φ41	Φ35	Φ30	45	

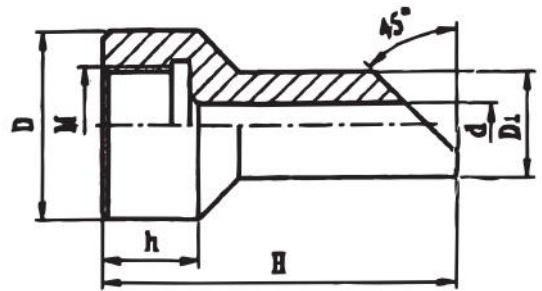

代号 Code	M	D	D <sub>1</sub>	d	h	H
TH49A	M27*2	Φ47	Φ28	Φ18	30	90
TH49B	M33*2	Φ55	Φ36	Φ24	30	150
TH49C	NPT1/2	Φ39	Φ27	Φ16	30	90
TH49D	NPT3/4	Φ47	Φ31	Φ20	35	90
TH49E	NPT1	Φ47	Φ41	Φ30	40	150

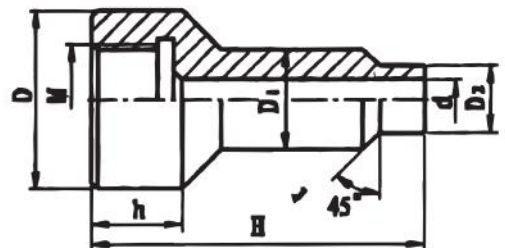

01T 型安装示意  
01T Mounting figure

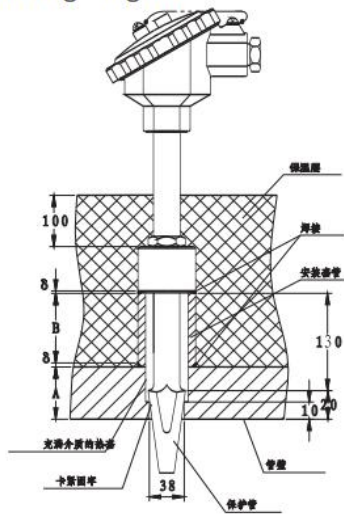

013T 型安装示意  
013T Mounting figure

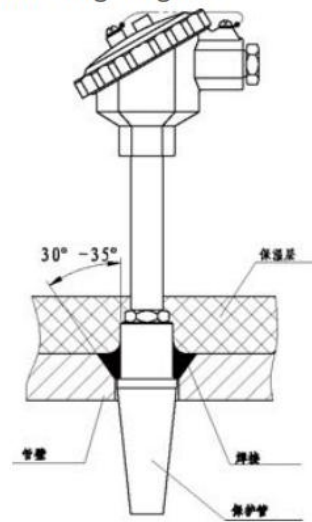

014T 型安装示意  
014T Mounting figure

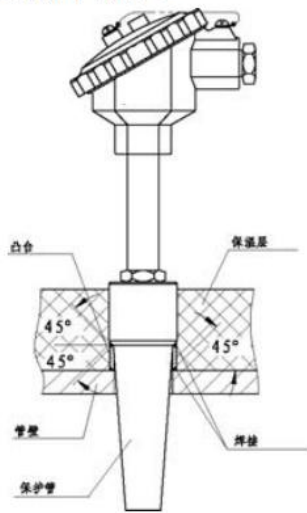

015T 型安装示意  
015T Mounting figure

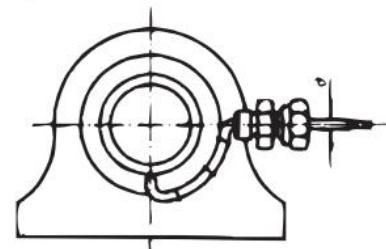
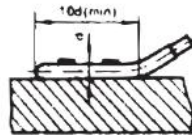
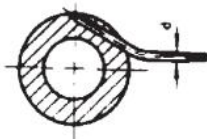
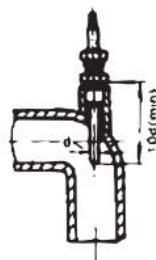
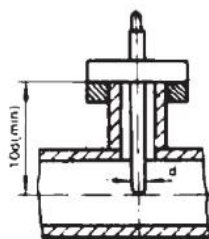
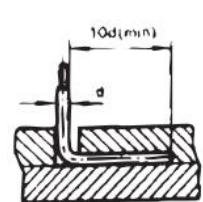
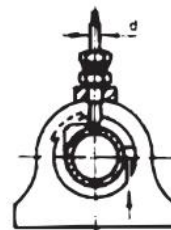
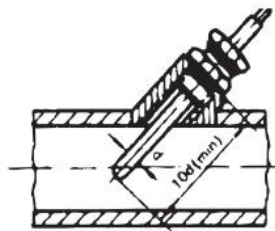
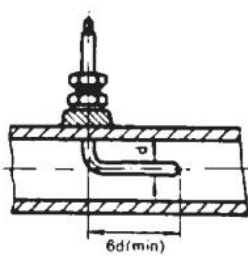
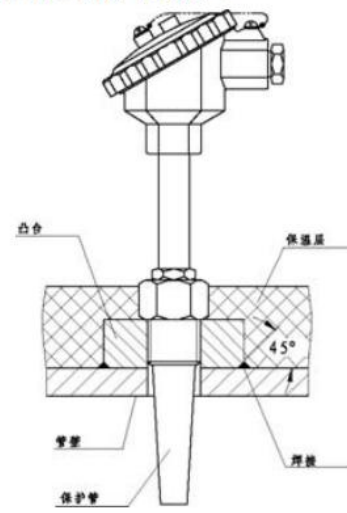

## 运输与贮存

热电阻及其附件在安装前必须贮存在不受震动和碰撞的地方，最合适的贮放场所条件为：环境温度 10-35℃、相对湿度不大于 80%，周围空气不含有可能造成热电阻零件腐蚀的杂质。

热电阻在长距离运输过程中应仔细地包装好。

## 可能发生的故障及其修理

序号	故障现象	可能原因	修理方法
1	显示仪表显示值比实际偏低或示值不稳定	保护管内有水或接线盒上有金属屑、灰尘或热电阻短路	(1) 倒出水或清除灰尘，并将潮湿部分加以干燥处理；提高绝缘（不能火烤）。 (2) 用万用电表检查断路或接地的部位，并清除之。
2	显示仪表显示值无限大	热电阻断路	(1) 用万用电表检查断路部位，确定是连接导线还是感温元件短路。 (2) 如系敏感元件断路应进行更换。
3	显示仪表显示下限值	(1) 热电阻短路 (2) 显示仪表接线错误	(1) 用万用电表检查确定短路部位，如系感温元件短路应进行修复或更换。 (2) 重新连接导线。



## Storage and transportation

Before fixing , the resistance thermometer sensor and its accessories should be stored away from vibration . The suitable ambient conditions for storage are as follows:temp. range from 10–35°C,relative humidity not more than 80% ,free from foreign substances that will cause corrosion.

During long-distance transportation, the resistance thermometer sensor should be well packaged.

## Troubleshooting

Order	Trouble	Possible cause	Remedy
1	The display value than practical value or is insteacy	There is water in the protective tube Metal crumbs or dust accumulated in terminal bead. The resistance thermometer sensor shortcircuited	1.Clear away water or dust and dry out the eamped part (dry by a fire is not allowed) 2.To rind out short-circuit with avometer and eliminste it if sesing element short-circuited it should be replaced
2	The readings of the display devive is infi nite	The wire in resistace thermometer sensor	1.To define whether the conductor or the sensing element is broken with avometer. 2.If the conductor is borken, It can be replaced or renovated.3.If the sensing element is broken, it should be replaced.
3	the diaplay device indicates	1.resistance thermometer sensor is short-circuit. 2.the wiring for the display device is incorrect	1.To deterring the short-circuit If the sensing element short-circuted 2.To rewire correctly.

**CN BOILER ENGINEERING SOLUTION LLC**

**ADD:** Building 7, No.16 Jinzhan Street, High&New Technology Development Zone, Zhengzhou City

**Tell:** 0371-56520101 17638563962

**Technical Service:** 17638562515 17638569108

**Email:** heidyhan89@cnboilersolution.com