



热电偶使用说明

INSTRUCTIONS OF THERMOCOUPLE



河南简控科技有限公司

CN BOILER ENGINEERING SOLUTION LLC

装配热电偶

Assembly Thermocouple

应用

通常和显示仪表、记录仪表、电子计算机等配套使用。直接测量各种生产过程中的 $0\text{ }^{\circ}\text{C}\sim 1300\text{ }^{\circ}\text{C}$ 范围内液体、蒸汽和气体介质以及固体表面温度。

特点

- 1、装配简单，更换方便；
- 2、压簧式感温元件，抗振性能好；
- 3、测量范围大；
- 4、机械强度高，耐压性能好；

工作原理

热电偶的电极由两根不同导体材质组成。当测量与参比端温差时，就会产生热电势，工作仪表便显示出热电势所对应的温度值。

主要技术参数

产品执行标准
IEC584
JB/T9238

常温绝缘电阻

热电偶在环境温度为 $20\pm 15\text{ }^{\circ}\text{C}$ ，相对湿度不大于 80%，试验电压为 $500\pm 50\text{V}$ （直流）电极与外套管之间的绝缘电阻 $\geq 1000\ \Omega\cdot\text{m}$

Application

It is usually connected with displaymeter, recording meter and computer, etc, to directly measure temperature of liquid, vapor, gas and solid surface ranging from $0\text{ }^{\circ}\text{C}$ to $1300\text{ }^{\circ}\text{C}$ during various production process.

Features

- 1、Easy assembly and convenient for replacement
- 2、Spring thermal element with good **shock-proof** performance
- 3、Wide measuring range
- 4、High mechanical **strength**, good **press-resistant** performance

Operation Theory

The electrodes of assembly thermocouple are made of different materials. The temperature difference between measuring end and reference end results in pyroelectric potential, then displaymeter indicates the corresponding temperature to the pyroelectric potential.

Main Technical Parameters

Executive Standard
IEC584
JB/T9238

Insulation Resistance at Normal Temperature

The insulation resistance between electrode and protection tube of assembly thermocouple shall be no than $1000\ \Omega\cdot\text{m}$ under condition that environment temperature is $20\pm 15\text{ }^{\circ}\text{C}$, relative is no more than 80%, and testing voltage is D.C. $500\pm 50\text{V}$

测温范围及允差

Measuring Range & Tolerance

型号 Type	分度号 Graduation	允差等级 Tolerance Class			
		I		II	
		允差值 Tolerance Value	测温范围℃	允差值 Tolerance Value	测温范围℃
WRN	K	± 1.5 °C	-40~+375	± 2.5 °C	-40~+333
		± 0.004 t	375~1000	± 0.0075 t	333~1200
WRM	N	± 1.5 °C	-40~+375	± 2.5 °C	-40~+333
		± 0.004 t	375~1000	± 0.0075 t	333~1200
WRE	E	± 1.5 °C	-40~375	± 2.5 °C	-40~333
		± 0.004 t	375~800	± 0.0075 t	333~900
WRF	J	± 1.5 °C	-40~+375	± 2.5 °C	-40~+333
		± 0.004 t	375~750	± 0.0075 t	333~750
WRC	T	± 1.5 °C	-40~+125	± 1 °C	-40~+133
		± 0.004 t	125~350	± 0.0075 t	133~350

接线盒形式 Junction Box

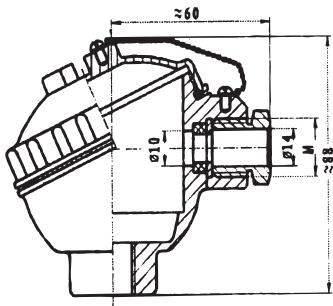

防喷式 Anti-spray Type

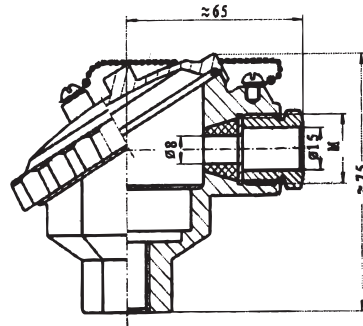

防水式 Water-proof Type

型号命名方法

Type Naming Method

W 温度仪表		Temperature Instrument							
R 热电偶		Thermocouple							
感温元件材料		Thermal Element Material							
N 锦络-锦硅	N	NiCr-NiSi							
M 锦络硅-锦硅	M	NiCrSi-NiSi							
E 锦络-铜硅	E	NiCr-CuSi							
C 铜-铜锦	C	Cu-CuNi							
F 铁-铜锦	F	Fe-CuNi							
偶丝对数		Filament							
无单支		blank Simplex							
2双支		2 Duplex							
安装固定形式		Mounting & Fixing							
1、无固定装置		1 without Fixing Device							
2、固定螺纹		2 Threaded Connector							
3、活动法兰		3 Movable Flange							
4、固定法兰		4 Fixed Flange							
5、活络管接头式		5 Elbow Tube Connection							
6、固定螺纹推形式		6 Threaded Cone Connector							
7、直形管接头式		7 Sraight Tube Connection							
8、固定螺纹管接头式		8 Fixed Threaded Tube Connection							
9、活动螺纹管接头式		9 Movable Threaded Tube Connection							
接线盒形式		Junction Box							
1、防喷式		2 Anti-spray Type							
2、防水式		3 Water-proof Type							
保护管直径		Protection Tube Diameter							
0 Φ 16		0 Φ 16							
1 Φ 20		1 Φ 20							
2 Φ 16 高铝质管		2 Φ 16 High Al Content Tube							
3 Φ 20 高铝质管		3 Φ 20 High Al Content Tube							
工作端形式		i b Measuring End							
G 变截面		G Var ■ ■ Cross Section							
W	R	N	2	-2	3	1	G	典型型号示例	Model Example

铠装热电偶

Armored Thermocouple

应用

通常和显示仪表、记录仪表、电子计算机等配套使用。直接测量各种生产过程中的0℃~1300℃范围内液体、蒸汽和气体介质以及固体表面温度。

特点

- 1、热响应时间少，减少动态误差；
- 2、可弯曲安装使用；
- 3、测量范围大；
- 4、机械强度高，耐压性能好；

工作原理

铠装热电偶的电极由两根不同导体材质组成。当测量端与参比端存在温差时，就会产生热电势，工作仪表便显示出热电势所对应的温度值。

主要技术参数

产品执行标准

IEC584

GB/T18404

常温绝缘电阻

铠装热电偶在环境温度为20±15℃，相对湿度不大于80%，试验电压为500~50V(直流)电极与外套管之间的绝缘电阻 $\geq 1000 \Omega \cdot m$ 。

即1M长的试样的绝缘电阻为1000M Ω ；

10 M长的试样的绝缘电阻为100M Ω ；

Application

It is usually connected with display meter, recording meter and computer, etc, to directly measure temperature of liquid, vapor, gas and solid surface ranging from 0℃ to 1300℃ during various production process.

Features

- 1、With quick response, reducing dynamic error
- 2、Optional installation methods
- 3、Wide measuring range
- 4、High mechanical strength, good press-resistant performance

Operation Theory

The electrodes of assembly thermocouple are made of different materials. The temperature difference between measuring end and reference end results in pyroelectric potential, then displaymeter indicates the corresponding temperature to the pyroelectric potential.

Main Technical Parameters

Executive Standard

IEC584

GB/T18404

Insulation Resistance at Normal Temperature

The insulation resistance between electrode and protection tube of armored thermocouple is no less than 100M. Ω under condition that environment temperature is 20±15℃, relative humidity is no more than 80%, and voltage is D.C. 500~50V.

The insulation resistance of 1 M long tested sample is 1000 $\Omega \cdot m$, and than of 10 M long tested sample is 1000 $\Omega \cdot m$;

测温范围及允差 Measuring Range & Tolerance

型号 Type	分度号 Graduation	允差等级 Tolerance Class			
		I		II	
		允差值 Tolerance Value	测温范围℃	允差值 Tolerance Value	测温范围℃
WRNK	K	± 1.5 °C	-40~+375	± 2.5 °C	-40~+333
		± 0.004 t	375~1000	± 0.0075 t	333~1200
WRMK	N	± 1.5 °C	-40~+375	± 2.5 °C	-40~+333
		± 0.004 t	375~1000	± 0.0075 t	333~1200
WREK	E	± 1.5 °C	-40~375	± 2.5 °C	-40~333
		± 0.004 t	375~800	± 0.0075 t	333~900
WRFK	J	± 1.5 °C	-40~+375	± 2.5 °C	-40~+333
		± 0.004 t	375~750	± 0.0075 t	333~750
WRCK	T	± 0.5 °C	-40~+125	± 1 °C	-40~+133
		± 0.004 t	125~350	± 0.0075 t	133~350
WRPK	S	± 1 °C	0~+1100	± 1.5 °C	0-600
		± [1+0.003(t-1100)]	1100~1600	± 0.0025 t	600-1600

偶丝直径及材料 Filament Diameter & Material

偶丝形式 Filament Form		单支式 simplex ○	双支式 duplex ○
装管直径 Tube Diameter		Φ2 Φ3 Φ4 Φ5 Φ6 Φ8	Φ3 Φ4 Φ5 Φ6 Φ8
套管材质 Tube Material	E、J、T	1Cr18Ni9Ti	1Cr18Ni9Ti
	K、N	1Cr18Ni9Ti GH3030	1Cr18Ni9Ti GH3030
	S	GH3039	GH3039

安装固定形式 Installation Figure

卡套螺纹接头 threaded head with fastener

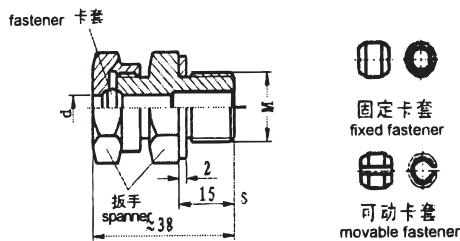

卡套法兰盘 flange with fastener

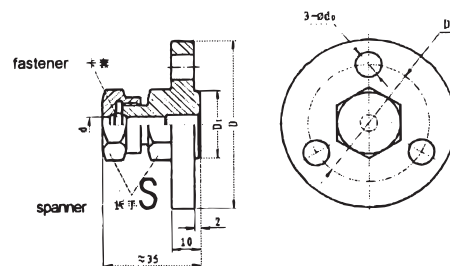

代号和尺寸 Code & Size	铠装偶外径 Outer Diameter of Armored Thermocouple					
	Φ8	Φ6	Φ5	Φ4	Φ3	Φ2
M	M16 × 1.5			M12 × 1.5		
S	22			19		

代号和尺寸 Code & Size	铠装偶外径 Outer Diameter of Armored Thermocouple					
	Φ8	Φ6	Φ5	Φ4	Φ3	Φ2
D	Φ60			Φ50		
D0	Φ42			Φ36		
D1	Φ24			Φ20		
S	Φ22			Φ19		
d0	Φ9			Φ7		

测量端结构形式 Measuring End Structure

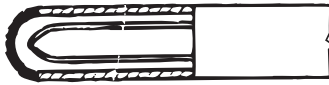

绝缘式
Insulation Type

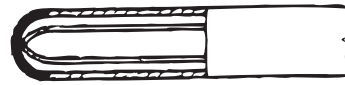

接壳式
Shell-connecting Type

附加装置形式 Attached Devices

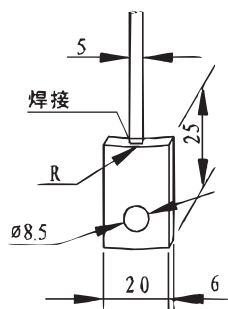

接触块式 (代号 M)
Contacting Block Type (Code M)

注: 选型时应注明 R 大小 (即管壁或炉壁直径)
Remarks: Size R should be indicated in ordering (diameter of tube wall or boiler wall)

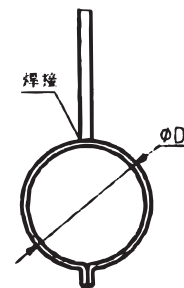

包箍式(代号 G)
Hoop Type (Code G)

接线盒方式 Juction Box Figures

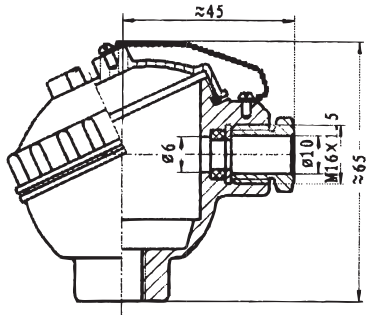

防喷式 Anti-spray Type

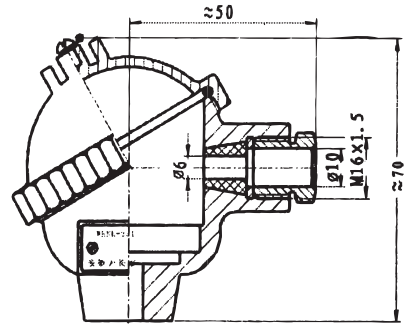

防水式 Water-proof Type

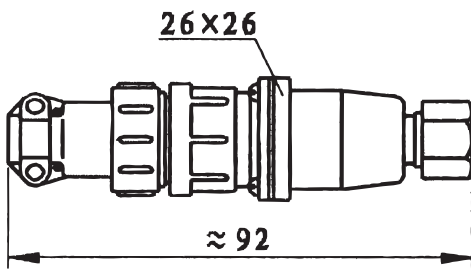

圆接插式 Round Plug Type

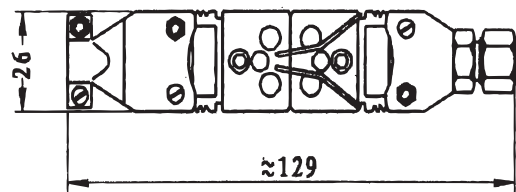

扁接插式 Flat Plug Type

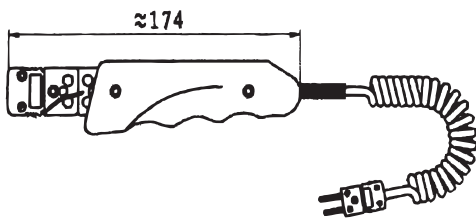

手柄式 Handle Type

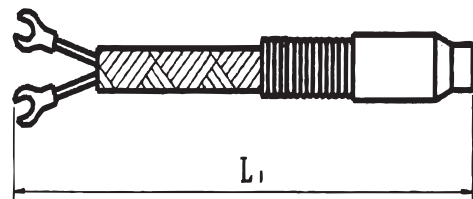

带补偿导线式 with Compensational Wire

铠装热电偶推荐使用温度

Operation Temperature Recommended of Armored Thermocouple

品种 Category	套管材料 Tube Material	外径 Outer Diameter	使用温度 (°C) Operation Temperature	
			长期使用 Long Term	短期使用 Short Term
镍铬 - 镍硅 NiCr-NiSi	1Cr18Ni9Ti	2.0	600	700
		3.0,4.0,5.0,6.0,8.0	800	900
	GH3030	2.0,3.0	800	900
		4.0,5.0	900	1000
		6.0,8.0	1000	1100
镍铬硅 - 镍硅 NiCrSi-NiSi	1Cr18Ni9Ti	2.0	600	700
		3.0,4.0,5.0,6.0,8.0	800	900
	GH3030	2.0,3.0	900	1000
		4.0,5.0	1000	1100
		6.0,8.0	1100	1200
GH3039	2.0,3.0,4.0	1000	1100	
	5.0,6.0,8.0	1100	1200	
镍铬 - 铜镍 NiCr-CuNi	1Cr18Ni9Ti	2.0	500	600
		3.0,4.0,5.0	600	700
		6.0,8.0	700	800
铁 - 铜镍 Fe-CuNi	1Cr18Ni9Ti	2.0	400	500
		3.0,4.0,5.0	500	600
		6.0,8.0	600	750
铜 - 铜镍 Cu-CuNi	1Cr18Ni9Ti	2.0,3.0,4.0	250	300
		6.0,8.0	300	350
铂铑 10 铂 PtRh10-Pt	GH3039	2.0,3.0,4.0	1000	1100
		5.0,6.0,8.0	1100	1200

型号命名方法

Type Naming Method

W 温度仪表		W Temp t Instrument							
R 热 偶		R Thermocouple							
感温元件材料		Thermal Element Material							
P	铂铑 ₁₀ -铂	P	RtRh ₁₀ -Pt						
M	铂铑硅-铂硅	M	NiCrSi-NiSi						
N	铂铑-铂硅	N	NiCr-NiSi						
E	铂铑-铜铂	E	NiCr-CuNi						
C	铜-铜铂	C	Cu-CuNi						
F	铁-铜铂	F	Fe-CuNi						
K 铠装式		K Armored Type							
偶丝对数		Filament							
	无单支	blank	Simplex						
	2双支	2	Duplex						
安装固定形式		Mounting & Fixing							
1	无固定装置	1	Without Fixing Device						
2	固定卡套螺纹	2	Threaded Head with Fixed Fastener						
3	活动卡套螺纹	3	hreaded Head with Movable Fastener						
4	固定卡套螺纹	4	Flange with Fixed Fastener						
5	活动卡套法兰	5	Flang with Movable Fastener						
接线盒形式		Junction Box Types							
2	防喷式	2	Anti-spray Type						
3	防水式	3	Water-proof Type						
6	圆接插式	6	Round Plug Type						
7	扁接插式	7	Flat Plug Type						
8	手柄式	8	Handle Type						
9	补偿导线式	9	with Compensational Wire						
工作端形式		Junction Box Types							
1	绝缘式	1	Insulation Type						
2	接壳式	2	Shell-connecting Type						
附加装置形式		Attached Devices							
M	接触块式	M	Contacting Block Type						
G	包箍式	G	Hoop Type						
W	R	N	2	-2	3	1	M	典型型号示例	Model Example

隔爆热电偶

Explosion-proof Thermocouple

应用

通常和显示仪表、记录仪表、电子计算机等配套使用。直接测量生产现场存在碳氢化合物等爆炸物的 0℃~1300℃ 范围内液体、蒸汽和气体介质以及固体表面温度。

特点

- 1、多种防爆形式，防爆性能好；
- 2、压簧式感温元件、抗振性能好；
- 3、测量范围大；
- 4、机械强度高，耐压性能好；

工作原理

防爆热电偶是利用间隙爆原理，设计具有足够强度的接线盒等部件，将所有会产生火花、电弧和危险温度的零部件都密封在接线盒腔内，当腔内发生爆炸时，能通过接合面间隙熄火和冷却，使爆炸后的火焰和温度传不到腔外，从而进行隔爆。

主要技术参数

产品执行标准

IEC584

JB/T5518-1991

GB3536

常温绝缘电阻

热电偶在环境温度为 $20 \pm 15^\circ\text{C}$ ，相对湿度不大于 80%，试验电压为 $500 \pm 50\text{V}$ （直流）电极与外套管之间的绝缘电阻 $\geq 1000\text{M}\Omega \cdot \text{m}$

Application

It is usually connected with display meter, recording meter and computer, etc., to directly measure temperature of liquid, vapor, gas and solid surface ranging from 0°C to 1300°C with explosives such as hydrocarbon on production spot.

Features

- Various explosion-proof types, good explosion-proof performance
- Spring thermal element with good shock-resistant performance
- wide measuring range
- High mechanical strength, good pressure-resistant performance

Operation Theory

Explosion-proof thermocouple has a junction box of enough strength with gaps inside it. All spare parts which might produce spark, electric arc, and dangerous high temperature are sealed in the junction box. When explosion within the box happens, fire and high temperature caused by explosion could be extinguished and cooled with the gap. Thus, explosion separation could be realized.

Main Technical Parameters

Executive Standard

IEC584

JB/T5518-1991

GB3836

Insulation Resistance at Normal Temperature

The insulation resistance between electrode and protection tube of the thermocouple shall be no less than $1000\text{M}\Omega \cdot \text{m}$ under condition that environment temperature is $20 \pm 15^\circ\text{C}$, relative humidity is no more than 80%, and testing voltage is D.C. $500\text{V} \pm 50\text{V}$

测量范围及允差

Measuring range & Tolerance

型号 Type	分度号 Graduation	允差等级 Tolerance Class			
		I		II	
		允差值 Tolerance Value	测温范围 Measuring Range °C	允差值 Tolerance Value	测温范围 °C
WRN	K	± 1.5 °C	-40~+375	± 2.5 °C	-40~+333
		± 0.004 t	375~1000	± 0.0075 t	333~1200
WRM	N	± 1.5 °C	-40~+375	± 2.5 °C	-40~+333
		± 0.004 t	375~1000	± 0.0075 t	333~1200
WRE	E	± 1.5 °C	-40~375	± 2.5 °C	-40~333
		± 0.004 t	375~800	± 0.0075 t	333~900
WRF	J	± 1.5 °C	-40~+375	± 2.5 °C	-40~+333
		± 0.004 t	375~750	± 0.0075 t	333~750
WRC	T	± 0.5 °C	-40~+125	± 1 °C	-40~133
		± 0.004 t	125~350	± 0.0075 t	133~350

防爆分组形式

Indication of Explosion-proof Function

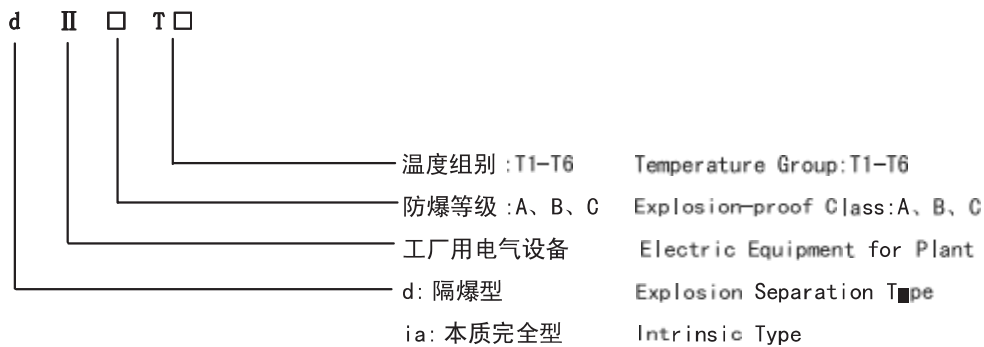

电气设备类别

- I 类——煤矿井下用电气设备
- II 类——工厂用电气设备

Electric Equipment Category

- I - Electric Equipment for Coal Mine Well
- II - Electric Equipment for Plant

防爆等级

防爆热电偶的防爆等级按其使用爆炸性气体混合物最大试验安全间隙分为 A、B、C 三级。

Explosion-proof Class

It is divided into grade A, Band C according to maximum test safety gap in explosive gas compound.

类别 Category	级别 Class	最大试验安全间隙 (MESG) mm Max. Test Safety G p
II	A	0.9 ≤ MESG
	B	0.5 < MESG < 0.9
	C	MESG ≤ 0.5

温度组别

防爆热电偶的温度组别按其外露部分允许最高面温度分为 T1-T6

温度组别 Temperature Group	允许最高表面温度℃ Max Surface Temperature Allowed
T1	450
T2	300
T3	200
T4	135
T5	100
T6	85

Temperature Group

It includes T1-T6 according to the maximum temperature of open part.

防爆级别:

Explosion-proof Class

EXd II □ T □

EXia II □ T □

防护等级:

Protection Class

IP65

接线盒形式

Junction Box

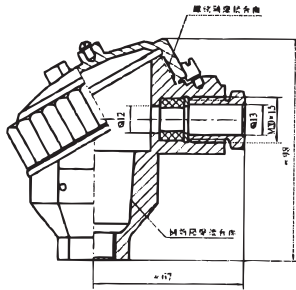

d II BT □级
Class d II BT □

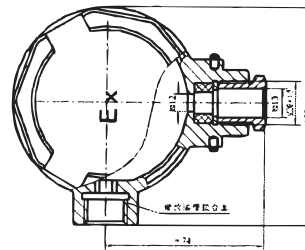

d II CT □级
Class d II CT □

安装端子形式

Terminal

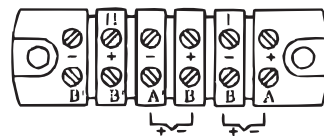
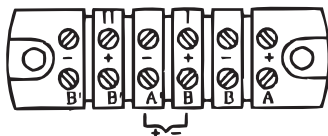

型号命名方法

Type Naming Method

W 温度仪表		W Temperature Instrument			
R 热电偶		R Thermocouple			
感温元件材料 M 锦络硅-锦硅 N 锦络-锦硅 E 锦络-铜锦 F 铁-铜锦 C 铜-铜锦		Thermal Element MaterialNiCrSi-NiSi NiCr- NiSi NiCr- CuNi Fe- CuNi Cu- CuNi			
偶丝对数 无 单支 2 双支		Filament blank Simplex 2 Duplex			
安装固定形式 1 无固定装置 2 固定螺纹 4 固定法兰 5 活络管接头式 7 直形螺纹管接头式 8 固定螺纹管接头式 9 活动螺纹管接头式		Mounting & Fixing 1 Without Fixing Device 2 Threaded Head with Fixed Fastener 4 Fixed Flange 5 Elbow Tube Connector 7 Straight Tube Connector 8 Fixed Threaded-tube Connector 9 Movable Threaded-tube Connector			
接线盒形式 4 防爆式		Junction Box 4 Explosion-proof Type			
保护管直径 0 Φ 16		Protection Tube Diameter 0 Φ 16			
工作端形式 G 变截面		Measuring End G Variable Cross Section			
W	R	N	2 -2 4 0 G	典型型号示例	Model Example

安装形式 Installation Figure

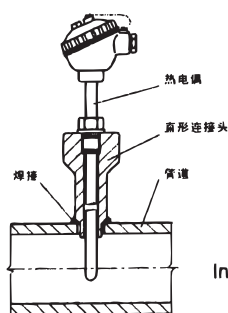

垂直管道安装形式
Installation in Horizontal
Tube

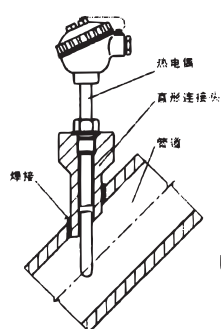

倾斜管道安装形式
Installation in Sliding
Tube

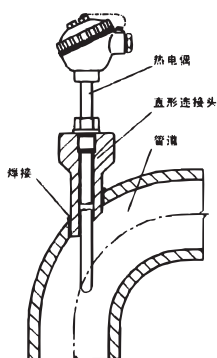

弯曲管道安装形式
Installation in
Bending Tube

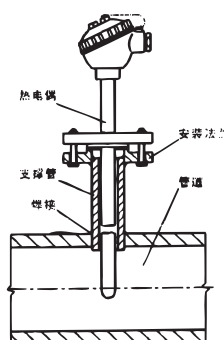

法兰安装形式
Flange Installation

直接接头 Straight Connector

代号 C d	M	D	D	D _I	d	h	H
TH48A	M12 1.5	Φ32	Φ18	Φ12	Φ7	27	60 120
TH48B	M16 1.5	Φ36	Φ18	Φ14	Φ7	27	80
TH48C	M20 1.5	Φ40	Φ18	Φ14	Φ7	27	60
TH48D	M27 2	Φ47	Φ28	Φ22	Φ17	32	60
TH48E	M33 2	Φ55	Φ36	Φ30	Φ21	34	120
TH48F	NPT1/2	Φ39	Φ27	Φ21	Φ16	35	60 120
TH48G	NPT3/4	Φ47	Φ31	Φ25	Φ20	40	
TH48H	NPT1	Φ47	Φ41	Φ35	Φ30	45	

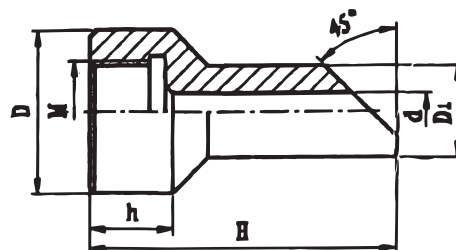

代号 Code	M	D	D _I	d	h	H
TH49A	M27 2	Φ47	Φ28	Φ18	30	90
TH49B	M3 2	Φ55	Φ36	Φ24	30	150
TH49C	NPT1/2	Φ39	Φ27	Φ16	30	90
TH49D	NPT3/4	Φ47	Φ31	Φ20	35	90
TH49E	NPT1	Φ47	Φ41	Φ30	40	150

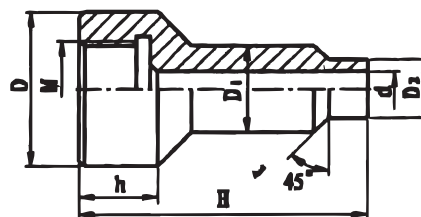

01T 型安装示意
0 1 T Mounting figure

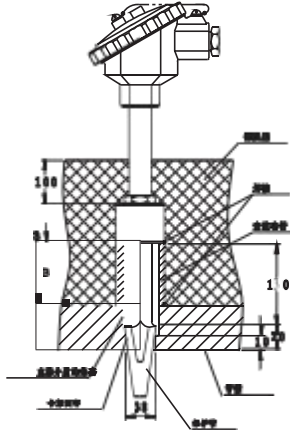

013T 型安装示意
0 1 3 T Mounting figure

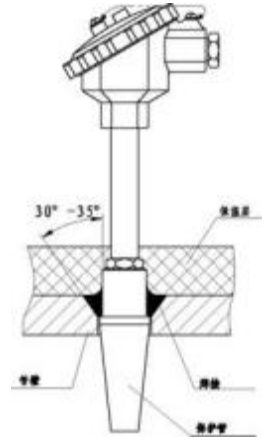

014T 型安装示意
0 1 4 T Mounting figure

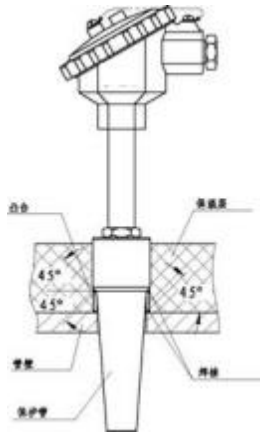

015T 型安装示意
0 1 5 T Mounting figure

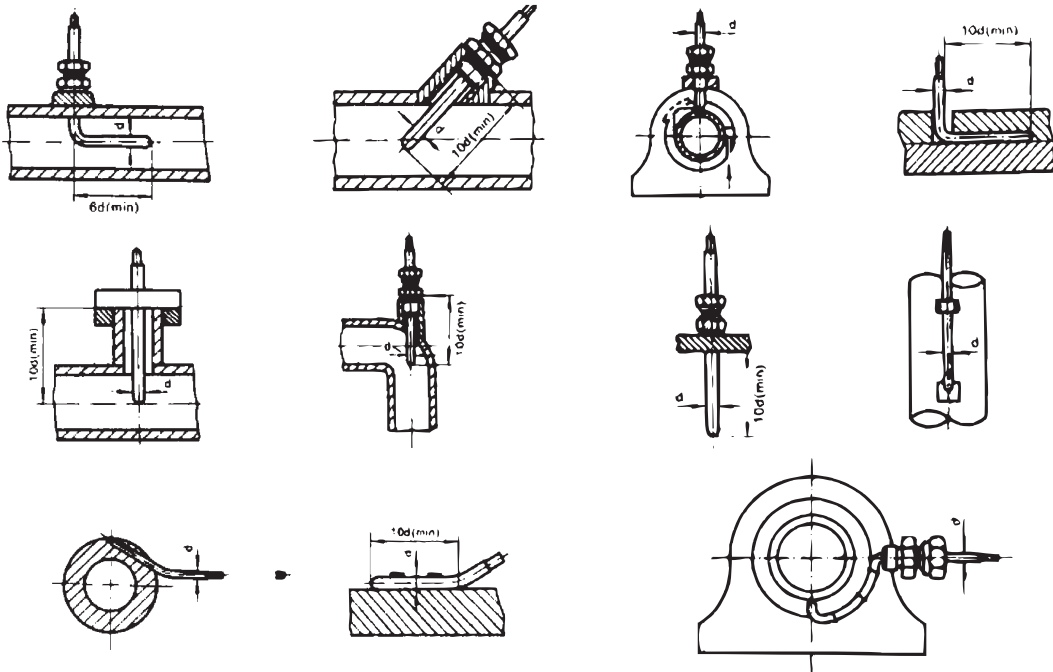
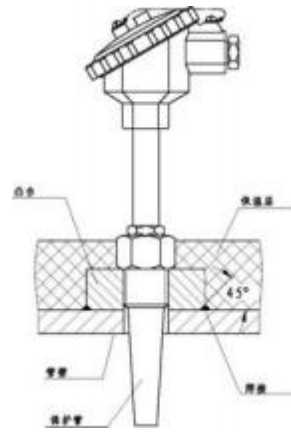

运输与贮存

热电阻及其附件在安装前,必须贮存在不受震动和碰撞的地方。最合适的贮存场所条件为环境温度10-35℃,相对湿度不大于80%,周围空气中不应含有可能使仪表零件腐蚀的介质。

Storage and transportation

Before fixing, the thermocouple and its accessories should be stored away from range shock. The suitable conditions for storage areas follows: temp from 10 °C to 35 °C relative humidity less than 80%; away from the corrosive circumstances.

During long-distance transportation, the thermocouple should be well packaged.

可能发生的故障及修理

序号	故障现象	可能原因	修理方法
1	热电动势比实际应有的小(测量仪表表示值偏低)	(1) 热电偶内部电极漏电(短路)。 (2) 热电偶内部潮湿。 (3) 热电偶接线盒内接线短路。 (4) 补偿导线短路。 (5) 热电偶热电极变质或测量端损坏。 (6) 补偿导线与热电偶的种类配置错误。 (7) 补偿导线与热电偶的极性接反。 (8) 热电偶安装位置或受热长度不当。 (9) 热电偶参比端温度过高。 (10) 热电偶种类与仪表刻度不一致。	(1) 将热电偶的热电极取出,检查漏电原因,若因潮湿引起,应将热电极烘干,若是因保护管绝缘不良引起,应即予更换。 (2) 将热电偶之热电极取出,把热电偶保护管和热电极分别烘干,并检查保护管是否漏气,漏水等情况,对不合格的保护套管应予更换。 (3) 打开接线盒盖,清洁接线板,消除造成断路的原因,把接线盒严密拧紧。 (4) 将短路处重新绝缘或更换补偿导线。 (5) 把变质部分剪去,重新焊接测量端或更换新的热电极。 (6) 换成与热电偶同种类的补偿导线。 (7) 重新改接。 (8) 改变安装位置或方法及插入深度。 (9) 准确地进行参比端温度补偿。 (10) 更换热电偶及补偿导线,使之与测量仪表种类相同。
2	热电动势比实际应有的大(测量仪表表示值偏高)	(1) 热电偶种类用错,与测量仪表不符。	(1) 更换热电极,使之与测量仪表相符。

序号	故障现象	可能原因	修理方法
2	热电动势比实际应有的大 (测量仪表表示值偏高)	(2) 补偿导线与热电偶种类不符。 (3) 热电偶安装方法、位置或插入深度不当。	(2) 换成与热电偶同类的补偿导线。 (3) 改变热电偶安装方法、位置或插入深度。
3	测量仪表的示值不稳定(在测量仪表无故障情况下)	(1) 热电偶接线柱和热电极接触不良。 (2) 热电偶有断续短路或断续接地现象。 (3) 热电极已断, 或将断未断而有时断时连现象。 (4) 热电偶安装不牢固, 发生摆动。 (5) 补偿导线有接地、断续路或断路现象。	(1) 清洁接线盒和热电偶端部重新连接好。 (2) 将热电极从保护管中取出, 找出断续短路或接地地方, 加以排除。 (3) 重新焊接断开处, 并检查其特性有否改变, 对不合要求的应予更换。 (4) 将热电偶牢固安装。 (5) 找出接地、断续短路处以修理或更换新的补偿导线。
4	热电偶热电动势变化	(1) 热电极变质 (2) 热电偶的安装位置或方法不当 (3) 热电偶保护管表面积垢过多。	(1) 更换新电极。 (2) 改变安装位置或方法。 (3) 拆下热电偶, 清除保护管外面积垢。

Troubleshooting

order	Trouble	Possible cause	Remedy
1	The thermal electromotive force is smaller than it should be (the value indicated by the measuring instrument is low)	(1) The thermocouple is short circuited . (2) there is moisture within the thermocouple . (3) the terminal in the terminal head short circuited . (4) The compensating wire short circuited . (5) Thermoelements have been deteriorated or measuring junction or measuring junction has been damaged . (6) The compensating wires do not match the thermocouple .	(1) Take out and check thermoelements, if is caused by dampdry out the thermoelements; if it is caused by poor insulation, porcelain tubes should be replaced . (2) Take out the thermoelements and dry out the protective tube and the thermoelements separately, then check the leakage of protective tube should be replaced . (3) Open the terminal head and clean the cause of shortcircuit, then terminal head . (4) nsulate the short- circuited part or change the compensation wires .

order	Trouble	Possible cause	Remedy
1		<p>(7) The reverse polarity between the compensating wire and thermoelement</p> <p>(8) Fixing place or heated length is not appropriate .</p> <p>(9) the temp at reference junction is too high .</p> <p>(10) The type of thermocouple is not identical with the graduation of display device</p>	<p>(5) Cut the deteriorated part off and resoldered the measuring junction or replace the thermoelements .</p> <p>(6) Use appropriate compensating wires .</p> <p>(7) Make reconnection correctly.</p> <p>(8) Change the fixing place or method and insert depth .</p> <p>(9) Compensate the temp, at reference junction correctly.</p> <p>(10) Change the thermocouple and compensating wires to match measuring instruments .</p>
2	The thermoEMF is greater than the practical value (the display value is higher than the practical value)	<p>(1) The type of thermocouple do not conform to the meter.</p> <p>(2) The compensating cables do not conform to the thermocouple type .</p> <p>(3) The fixing method place and insert depth is not proper.</p>	<p>(1) Clean the terminal box and the ends of thermoelements and reconnect them .</p> <p>(2) Take out the elements from the protective tube and eliminate the cause .</p> <p>(3) Joint the broken thermo</p>
3	The reading of the display instrument are not stable (without failures)	<p>(1) Poor contact between terminal and thermoelement for the thermocouple .</p> <p>(2) The thermocouple is in intermittent shortcircuit or earthing condition .</p>	<p>(1) Change the thermocouple to match the meter.</p> <p>(2) Change the compensating cable</p> <p>(3) Change the method, place and insert depth .</p>

order	Trouble	Possible cause	Remedy
3		<p>(3) The thermoelements have broken or is on and off fixed firmly.</p> <p>(4) The thermocouple is not fixed firmly.</p> <p>(5) The compensating wire been has earthedshotcircuited or broken intermittlely.</p>	<p>elements and check its property.</p> <p>Replace it when necessary.</p> <p>(4) Repair or replace the compensating wire</p>
4	The thermoemf is varying	<p>(1) The thermoelement has deteriorated .</p> <p>(2) The fixing place or method is not appropriate .</p> <p>(3) More scale depositad on the surface of protective</p>	<p>(1) Replace it with a new one .</p> <p>(2) Change the place or method .</p> <p>(3) Remove the thermocouple and clean outside wall of the protective tube .</p>

注：当发生以上故障情况时，应将补偿导线和接线盒分开，分别检查热电偶与补偿导线，待确定故障后，再进行处理。

note: When above failures happen in the thermocouple, compensating wire should be disconnected from the terminal head firstly, then check the thermocouple and compensating cables separately and handle the failure when it is determined.

CN BOILER ENGINEERING SOLUTION LLC

ADD: Building 7, No.16 Jinzhan Street, High&New Technology Development Zone, Zhengzhou City

Tell: 0371-56520101 17638563962

Technical Service: 17638562515 17638569108

Email: heidyhan89@cnboilersolution.com